

**RIGHT-ANGLE PRECISION
BEVEL GEAR DRIVES**



RIGHT-ANGLE PRECISION BEVEL GEAR DRIVES

CHT-RB and CHT-RP right-angle drives are designed for industrial applications where rotary power must be transferred between two shafts at right-angles to each other. CHT-RB and CHT-RP are available in many different sizes with 2 or 3 outputs and 1/1 - 1/2 - 1/3 transmission ratios.

Right-angle identification:

The following tables show: the shaft diameter, the transmission ratio, the input shaft, the output shafts B-C or D and the direction of rotation (looking at the shaft from the front).

SIZE	MOD. RB	CHT						
		SHAFT	RATIO	INPUT	OUTPUT	TYPE	CODE	WEIGHT Kg
1		Ø 8	1/1	A	B	1	R1081101	0.3
		Ø 8	1/1	A	C	2	R1081102	
		Ø 8	1/2	A	B	3	R1081203	
		Ø 8	1/2	A	C	4	R1081204	
		Ø 8	1/1	A	B-C	5	R1081105	
		Ø 8	1/2	A	B-C	6	R1081206	
2		Ø 15	1/1	A	B	1	R1151101	1.1
		Ø 15	1/1	A	C	2	R1151102	
		Ø 15	1/2	A	B	3	R1151203	
		Ø 15	1/2	A	C	4	R1151204	
		Ø 15	1/1	A	B-C	5	R1151105	1.2
		Ø 15	1/2	A	B-C	6	R1151206	
3		Ø 20	1/1	A	B	1	R1201101	3.4
		Ø 20	1/1	A	C	2	R1201102	
		Ø 20	1/2	A	B	3	R1201203	
		Ø 20	1/2	A	C	4	R1201204	
		Ø 20	1/1	A	B-C	5	R1201105	3.5
		Ø 20	1/2	A	B-C	6	R1201206	
4		Ø 25	1/1	A	B	1	R1251101	5.5
		Ø 25	1/1	A	C	2	R1251102	
		Ø 25	1/2	A	B	3	R1251203	
		Ø 25	1/2	A	C	4	R1251204	
		Ø 25	1/1	A	B-C	5	R1251105	5.8
		Ø 25	1/2	A	B-C	6	R1251206	



RIGHT-ANGLE PRECISION BEVEL GEAR DRIVES

SIZE	MOD. RP	CHT						WEIGHT Kg
		SHAFT	RATIO	INPUT	OUTPUT	TYPE	CODE	
1		Ø 8	1/1	A	B	1	R3081101	0.6
		Ø 8	1/1	A	C	2	R3081102	
		Ø 8	1/2	A	B	3	R3081203	
		Ø 8	1/2	A	C	4	R3081204	
		Ø 8	1/1	A	B-C	5	R3081105	
		Ø 8	1/2	A	B-C	6	R3081206	
2		Ø 14	1/1	A	B	1	R3141101	2
		Ø 14	1/1	A	C	2	R3141102	
		Ø 14	1/2	A	B	3	R3141203	
		Ø 14	1/2	A	C	4	R3141204	
		Ø 14	1/3	A	B	5	R3141305	
		Ø 14	1/3	A	C	6	R3141306	
		Ø 14	1/1	A	B-C	7	R3141107	
		Ø 14	1/2	A	B-C	8	R3141208	
		Ø 14	1/3	A	B-C	9	R3141309	
3		Ø 14	1/1	A	B-C	10	R3141110	1.9
		Ø 14	1/2	A	B-C	11	R3141211	
		Ø 14	1/3	A	B-C	12	R3141312	
4		Ø 14	1/1	A	B-C	13	R3141113	3.2
		Ø 14	1/1	A	C-D	14	R3141114	
		Ø 14	1/2	A	B-C	15	R3141215	
		Ø 14	1/2	A	C-D	16	R3141216	
		Ø 14	1/3	A	B-C	17	R3141317	
		Ø 14	1/3	A	C-D	18	R3141318	
		Ø 14	1/1	A	B-C-D	19	R3141119	
		Ø 14	1/2	A	B-C-D	20	R3141220	
		Ø 14	1/3	A	B-C-D	21	R3141321	
5		Ø 19	1/1	A	B	1	R3191101	4.5
		Ø 19	1/1	A	C	2	R3191102	
		Ø 19	1/2	A	B	3	R3191203	
		Ø 19	1/2	A	C	4	R3191204	
		Ø 19	1/3	A	B	5	R3191305	
		Ø 19	1/3	A	C	6	R3191306	
		Ø 19	1/1	A	B-C	7	R3191107	
		Ø 19	1/2	A	B-C	8	R3191208	
		Ø 19	1/3	A	B-C	9	R3191309	
6		Ø 19	1/1	A	B-C	10	R3191110	4.4
		Ø 19	1/2	A	B-C	11	R3191211	
		Ø 19	1/3	A	B-C	12	R3191312	
7		Ø 24	1/1	A	B	1	R3241101	4.6
		Ø 24	1/1	A	C	2	R3241102	
		Ø 24	1/2	A	B	3	R3241203	
		Ø 24	1/2	A	C	4	R3241204	
		Ø 24	1/3	A	B	5	R3241305	
		Ø 24	1/3	A	C	6	R3241306	
		Ø 24	1/1	A	B-C	7	R3241107	
		Ø 24	1/2	A	B-C	8	R3241208	
		Ø 24	1/3	A	B-C	9	R3241309	



TECHNICAL NOTES

Selecting the correct type of angle bevel gear is not simply a question of defining the power required in relation to R.P.M. and the torque to be transmitted. It also involves defining the conditions under which the angle bevel gear will be used. Defining operating conditions involves taking into consideration a number of factors such as the type of operating cycle (intermittent, continuous), radial and axial loads on the shaft ends, maximum and minimum temperatures, ambient conditions (e.g. dust and dirt levels) and the type of lubricant used. To decide the type and size of angle bevel gear required, proceed as follows.

- 1) Use table 1 to define the Service Factor for your application.
- 2) Calculate the Rated Power (P_n); $P_n = P_e$ (Horsepower) \times FS.
- 3) Use the output speed and the rated power (P_n) to select the angle gear size and transmission ratio required for your application.
- 4) Check that the radial and axial load at the midpoint of the exposed shaft end does not exceed the values shown in table external loads.
- 5) Check that the operating temperature does not exceed $-20^{\circ}\text{C} \div 80^{\circ}\text{C}$
- 6) If you require a 1/2 or 1/3 ratio, do not use a speed multiplier with an input more than 750 R.P.M. and 500 R.P.M. in ratio 1/2 and 1/3, respectively.
- 7) If the unit is to be used in very dusty conditions, protect the oil seal against direct exposure to dust to prevent abrasive damage which might shorten the working life of the unit.

TABLE 1

SERVICE FACTOR F_s

	hours of operation for day			
	3	8	12	24
uniform load	0.7	0.9	1	1.3
load with moderate shocks	0.9	1	1.3	1.8
load with shocks	1.3	1.6	1.8	2.3



INPUT POWER (Pn) Output torque T

Output speed		50 rpm	100 rpm	200 rpm	400 rpm	800 rpm	1400 rpm	2000 rpm	3000 rpm
Output torque		T power	T power	T power	T power	T power	T power	T power	T power
Type	Ratio	Nm Kw	Nm Kw	Nm Kw	Nm Kw	Nm Kw	Nm Kw	Nm Kw	Nm Kw
RB 1-1/2- RB 1-5	R 1:1	4,7 0,02	3,9 0,04	3,3 0,07	2,8 0,12	2,3 0,19	2,0 0,30	1,8 0,39	1,7 0,53
RP 1-1/2- RP 1-5		9,1 0,05	7,6 0,08	6,4 0,13	5,4 0,23	4,5 0,38	4,0 0,58	3,6 0,76	3,3 1,03
RB 2-1/2- RB 2-5		16,5 0,09	13,9 0,15	11,7 0,24	9,8 0,41	8,2 0,69	7,2 1,05	6,6 1,37	5,9 1,86
RP 3-10		28,8 0,15	24,2 0,25	20,3 0,43	17,1 0,72	14,4 1,20	12,5 1,83	11,4 2,39	10,3 3,25
RP 2-1/2		34,5 0,18	29,0 0,30	24,4 0,51	20,5 0,86	17,2 1,44	15,0 2,20	13,7 2,87	12,4 3,89
RP 4-13/14									
RP 2-7									
RP 4-19		53,1 0,28	44,6 0,47	37,5 0,79	31,6 1,32	26,5 2,22	23,1 3,38	21,1 4,42	19,1 5,99
RB 3-1/2									
RB 3-5		75,7 0,40	63,7 0,67	53,5 1,12	45,0 1,89	37,9 3,17	32,9 4,82	30,1 6,30	27,2 8,54
RP 6-10									
RB 4-1/2- RP 5-1/2	87,3 0,46	73,4 0,77	61,8 1,29	51,9 2,17	43,7 3,66	38,0 5,56	34,7 7,27	31,4 9,86	
RP 7-1/2- RB 4-5									
RP 5-7- RP 7-7									
RB 1-3/4- RB 1-6	R 1:2	4,0 0,02	3,4 0,04	2,8 0,06	2,4 0,10	2,0 0,17	1,7 0,26	1,6 0,33	1,4 0,45
RP 1-3/4- RP 1-6		8,9 0,05	7,5 0,08	6,3 0,13	5,3 0,22	4,4 0,37	3,9 0,57	3,5 0,74	3,2 1,00
RB 2-3/4- RB 2-6		14,6 0,08	12,3 0,13	10,3 0,22	8,7 0,36	7,3 0,61	6,3 0,93	5,8 1,21	5,2 1,65
RP 3-11		28,1 0,15	23,7 0,25	19,9 0,42	16,7 0,70	14,1 1,18	12,2 1,79	11,2 2,34	10,1 3,17
RP 2-3/4		33,8 0,18	28,5 0,30	23,9 0,50	20,1 0,84	16,9 1,42	14,7 2,16	13,5 2,82	12,2 3,82
RP 4-15/16									
RP 2-8									
RP 4-20		42,5 0,22	35,7 0,37	30,1 0,63	25,3 1,06	21,3 1,78	18,5 2,71	16,9 3,54	15,3 4,80
RB 3-3/4- RB 3-6									
RP 6-11		71,3 0,37	59,9 0,63	50,4 1,06	42,4 1,77	35,6 2,98	31,0 4,54	28,3 5,93	25,6 8,04
RB 4-3/4- RP 4-6									
RP 7-3/4- RB 4-6									
RP 5-8- RP 7-8	82,3 0,43	69,2 0,72	58,2 1,22	48,9 2,05	41,1 3,44	35,8 5,24	32,7 6,85	29,6 9,28	
RP 2-5/6	R 1:3	27,5 0,14	23,1 0,24	19,4 0,41	16,3 0,68	13,7 1,15	12,0 1,75	10,9 2,29	9,9 3,10
RP 2-9									
RP 3-12									
RP 4-17/18									
RP 4-21									
RP 5-5/6		63,4 0,33	53,3 0,56	44,9 0,94	37,7 1,58	31,7 2,66	27,6 4,04	25,2 5,28	22,8 7,16
RP 5-9									
RP 6-12									
RP 7-5/6									
RP 7-9									



RIGHT-ANGLE PRECISION BEVEL GEAR DRIVES

EXTERNAL LOADS IN CONNECTION WITH SPEED Fr = radial load Fa = axial load

Output speed		50 rpm		100 rpm		200 rpm		400 rpm		800 rpm		1400 rpm		2000 rpm		3000 rpm	
Radial - axial load		Fr	Fa	Fr	Fa	Fr	Fa	Fr	Fa	Fr	Fa	Fr	Fa	Fr	Fa	Fr	Fa
Type	Ratio	N	N	N	N	N	N	N	N	N	N	N	N	N	N	N	N
RB 1-1/2- RB 1-5	R 1:1	139	94	117	79	98	66	83	56	70	47	60	41	55	37	50	34
RP 1-1/2- RP 1-5		195	158	164	133	138	112	116	94	98	79	85	69	78	63	70	57
RB 2-1/2- RB 2-5		328	220	276	185	232	156	195	131	164	110	142	96	130	87	118	79
RP 3-10		430	348	361	293	304	246	256	207	215	174	187	151	171	139	154	125
RP 2-1/2		516	418	434	351	365	295	307	248	258	209	224	182	205	166	185	150
RP 4-13/14																	
RP 2-7		684	458	575	385	484	324	407	273	342	229	297	199	272	182	246	165
RP 4-19																	
RB 3-1/2		826	554	695	465	584	391	491	329	413	277	359	241	329	220	297	199
RB 3-5																	
RP 6-10	953	639	802	537	674	452	567	380	477	319	414	278	379	254	342	229	
RB 4-1/2 - RP 5-1/2																	
RP 7-1/2- RB 4-5																	
RP 5-7- RP 7-7																	
RB 1-3/4- RB 1-6	R 1:2	107	76	90	64	76	54	64	45	54	38	47	33	43	30	39	27
RP 1-3/4- RP 1-6		182	110	153	93	129	78	108	66	91	55	79	48	73	44	66	40
RB 2-3/4- RB 2-6		276	168	232	141	195	119	164	100	138	84	120	73	110	67	99	60
RP 3-11		370	263	311	221	262	186	220	157	185	132	161	114	147	105	133	95
RP 2-3/4		445	316	374	266	315	224	265	188	223	158	194	137	177	126	160	114
RP 4-15/16																	
RP 2-8		548	361	461	303	387	255	326	214	274	180	238	157	218	143	197	130
RP 4-20																	
RB 3-3/4- RB 3-6		696	422	585	355	492	299	414	251	348	211	303	184	277	168	250	152
RP 6-11																	
RB 4-3/4 - RP 4-6	803	483	675	406	568	341	478	287	402	241	349	210	319	192	289	173	
RP 7-3/4- RB 4-6																	
RP 5-8- RP 7-8																	
RP 2-5/6	R 1:3	357	199	301	167	253	141	213	118	179	99	155	86	142	79	128	71
RP 2-9																	
RP 3-12																	
RP 4-17/18																	
RP 4-21																	
RP 5-5/6		619	346	521	291	438	245	368	206	310	173	269	151	246	138	222	124
RP 5-9																	
RP 6-12																	
RP 7-5/6																	
RP 7-9																	



RIGHT-ANGLE PRECISION BEVEL GEAR DRIVES

SIZE 1 MOD. RB CHT

	RATIO	INPUT	OUTPUT	CODE	WEIGHT Kg
	1/1	A	B	R1081101	0.3
	1/1	A	C	R1081102	
	1/2	A	B	R1081203	
	1/2	A	C	R1081204	
	1/1	A	B-C	R1081105	
	1/2	A	B-C	R1081206	

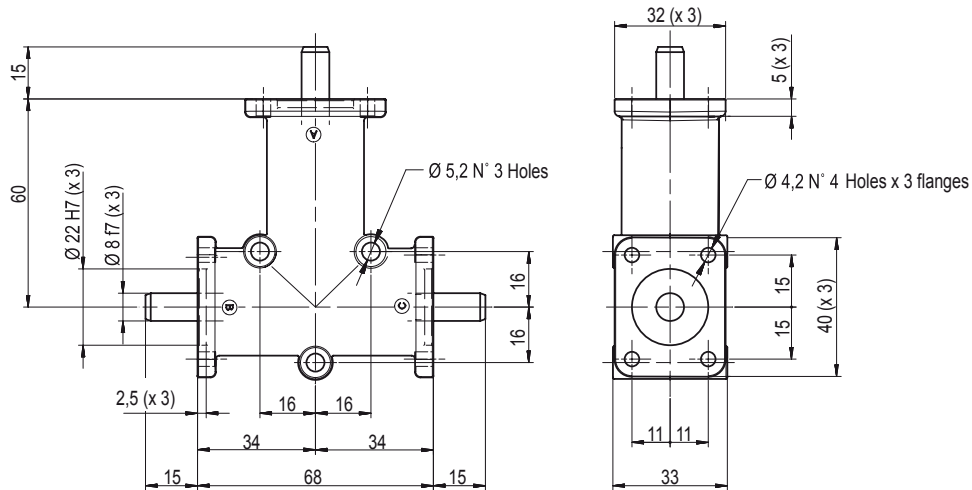

SIZE 2 MOD. RB CHT

	RATIO	INPUT	OUTPUT	CODE	WEIGHT Kg
	1/1	A	B	R1151101	1.1
	1/1	A	C	R1151102	
	1/2	A	B	R1151203	
	1/2	A	C	R1151204	
	1/1	A	B-C	R1151105	1.2
	1/2	A	B-C	R1151206	

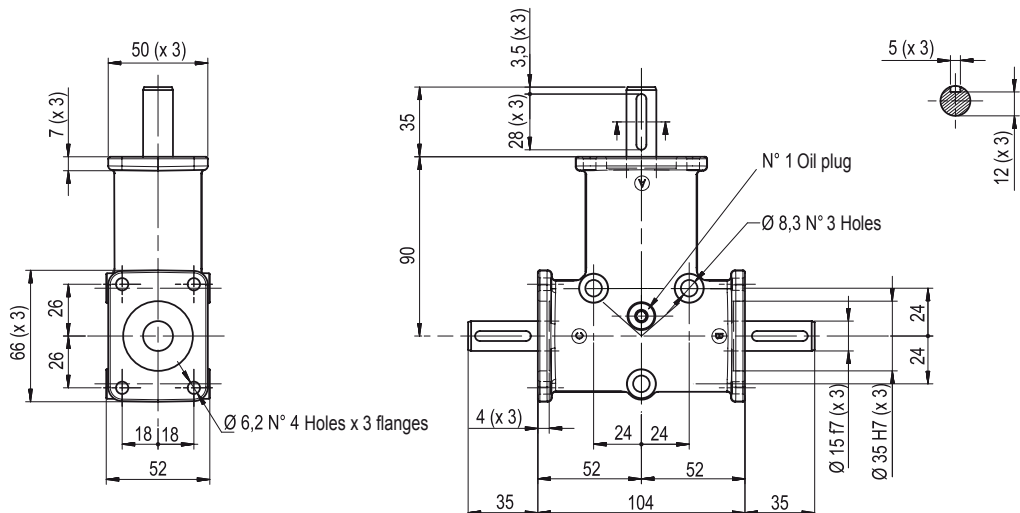



RIGHT-ANGLE PRECISION BEVEL GEAR DRIVES

SIZE 3

MOD. RB

CHT

	RATIO	INPUT	OUTPUT	CODE	WEIGHT Kg
	1/1	A	B	R1201101	3.4
	1/1	A	C	R1201102	
	1/2	A	B	R1201203	
	1/2	A	C	R1201204	
	1/1	A	B-C	R1201105	3.5
	1/2	A	B-C	R1201206	

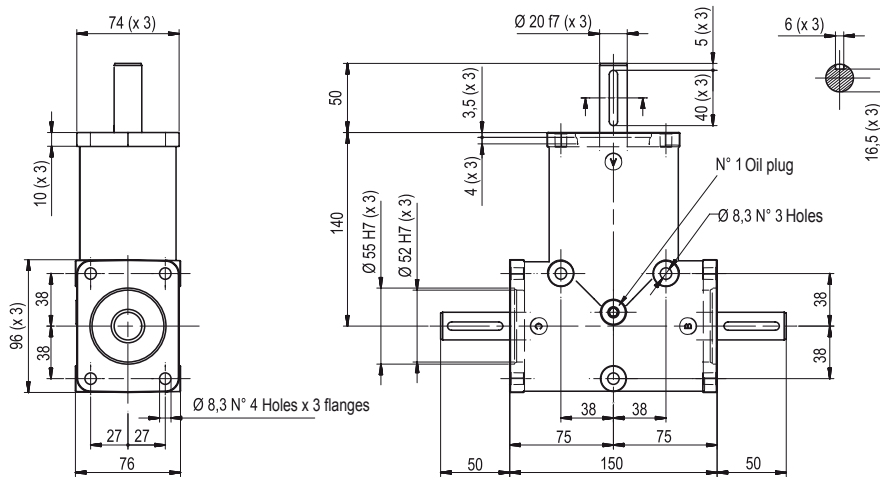

148

SIZE 4

MOD. RB

CHT

	RATIO	INPUT	OUTPUT	CODE	WEIGHT Kg
	1/1	A	B	R1251101	5.5
	1/1	A	C	R1251102	
	1/2	A	B	R1251203	
	1/2	A	C	R1251204	
	1/1	A	B-C	R1251105	5.8
	1/2	A	B-C	R1251206	

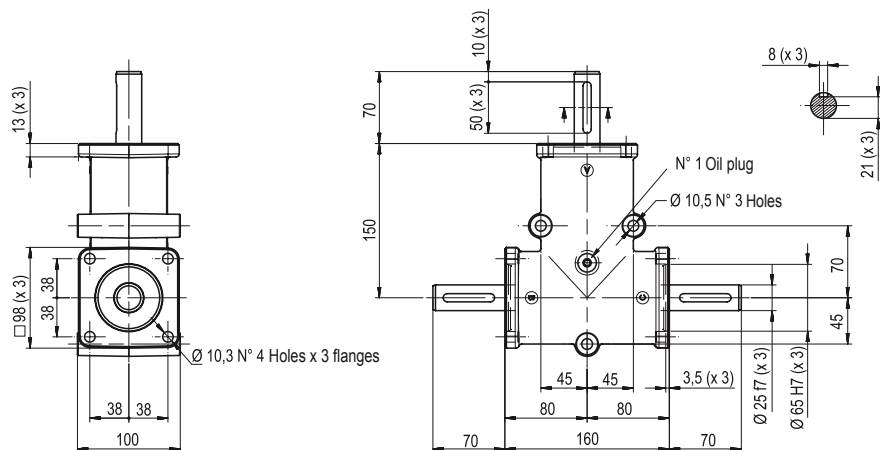



RIGHT-ANGLE PRECISION BEVEL GEAR DRIVES

SIZE 1 MOD. RP CHT

	RATIO	INPUT	OUTPUT	CODE	WEIGHT Kg
	1/1	A	B	R3081101	0.6
	1/1	A	C	R3081102	
	1/2	A	B	R3081203	
	1/2	A	C	R3081204	
	1/1	A	B-C	R3081105	
	1/2	A	B-C	R3081206	

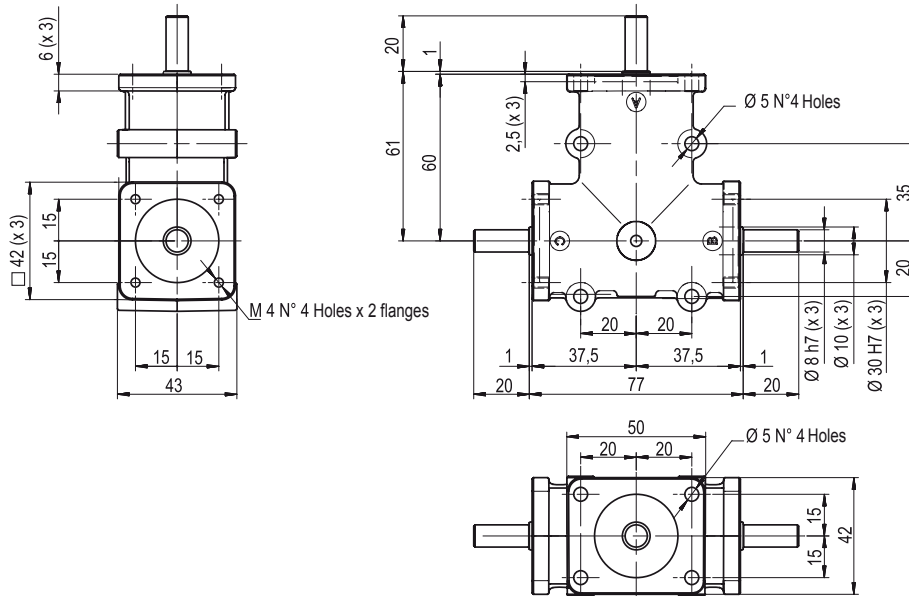

SIZE 2 MOD. RP CHT

	RATIO	INPUT	OUTPUT	CODE	WEIGHT Kg
	1/1	A	B	R3141101	2
	1/1	A	C	R3141102	
	1/2	A	B	R3141203	
	1/2	A	C	R3141204	
	1/3	A	B	R3141305	
	1/3	A	C	R3141306	
	1/1	A	B-C	R3141107	
	1/2	A	B-C	R3141208	
	1/3	A	B-C	R3141309	

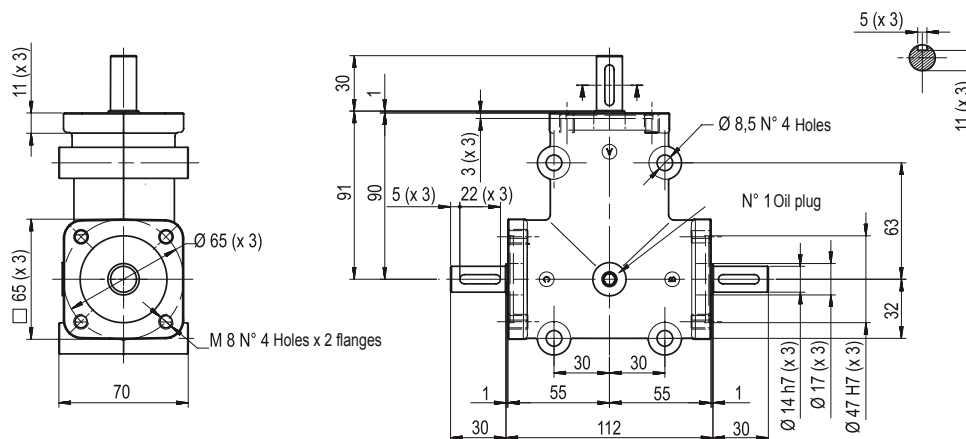



RIGHT-ANGLE PRECISION BEVEL GEAR DRIVES

SIZE 3

MOD. RP

CHT

	RATIO	INPUT	OUTPUT	CODE	WEIGHT Kg
	1/1	A	B-C	R3141110	2
	1/2	A	B-C	R3141211	
	1/3	A	B-C	R3141312	

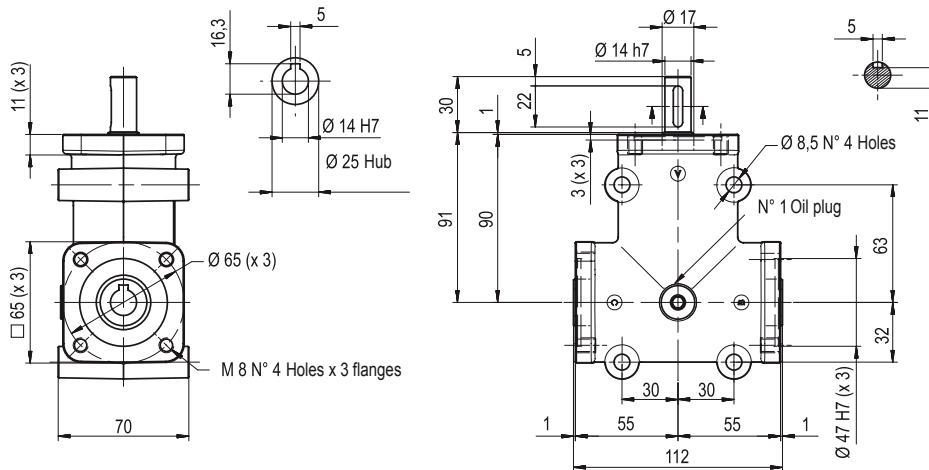

150

SIZE 4

MOD. RP

CHT

	RATIO	INPUT	OUTPUT	CODE	WEIGHT Kg
	1/1	A	B-C	R3141113	3.2
	1/1	A	C-D	R3141114	
	1/2	A	B-C	R3141215	
	1/2	A	C-D	R3141216	
	1/3	A	B-C	R3141317	
	1/3	A	C-D	R3141318	
	1/1	A	B-C-D	R3141119	
	1/2	A	B-C-D	R3141220	
	1/3	A	B-C-D	R3141321	

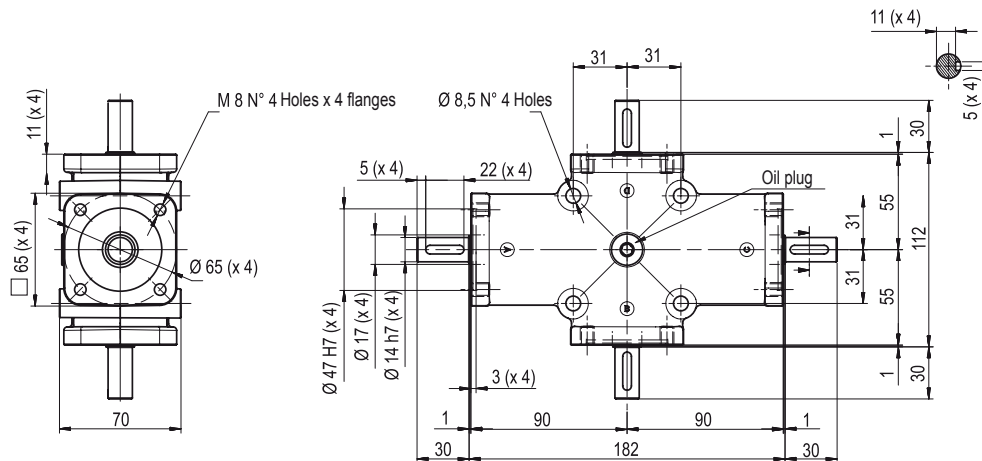



RIGHT-ANGLE PRECISION BEVEL GEAR DRIVES

SIZE 5

MOD. RP

CHT

RATIO

INPUT

OUTPUT

CODE

WEIGHT Kg

	RATIO	INPUT	OUTPUT	CODE	WEIGHT Kg
	1/1	A	B	R3191101	4.5
	1/1	A	C	R3191102	
	1/2	A	B	R3191203	
	1/2	A	C	R3191204	
	1/3	A	B	R3191305	
	1/3	A	C	R3191306	
	1/1	A	B-C	R3191107	
	1/2	A	B-C	R3191208	
	1/3	A	B-C	R3191309	

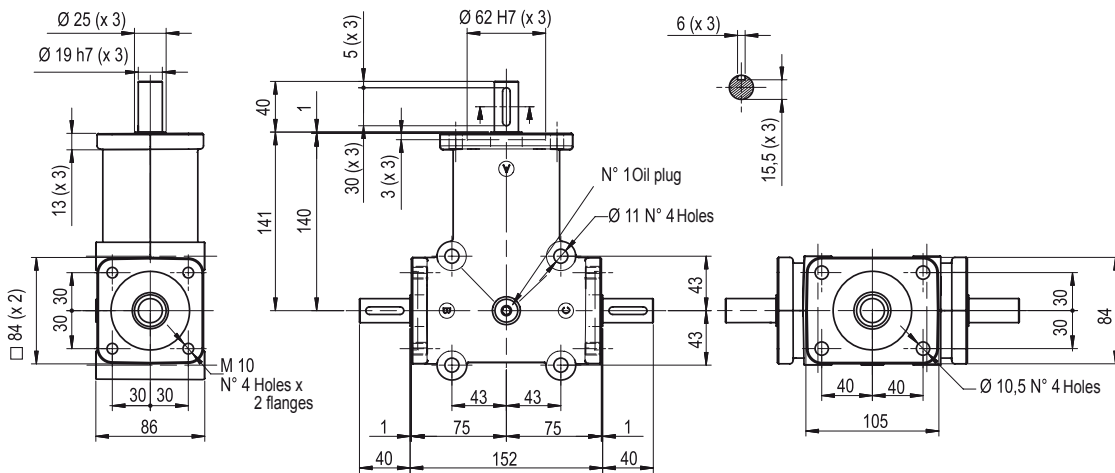

SIZE 6

MOD. RP

CHT

RATIO

INPUT

OUTPUT

CODE

WEIGHT Kg

	RATIO	INPUT	OUTPUT	CODE	WEIGHT Kg
	1/1	A	B-C	R3191110	4.5
	1/2	A	B-C	R3191211	
	1/3	A	B-C	R3191312	

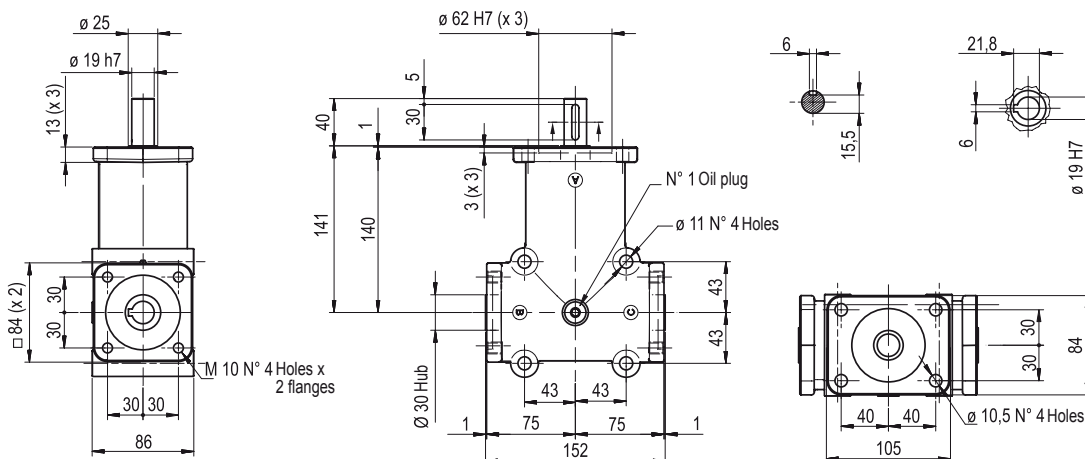



RIGHT-ANGLE PRECISION BEVEL GEAR DRIVES

SIZE 7

MOD. RP

CHT

	RATIO	INPUT	OUTPUT	CODE	WEIGHT Kg
	1/1	A	B	R3241101	4.5
	1/1	A	C	R3241102	
	1/2	A	B	R3241203	
	1/2	A	C	R3241204	
	1/3	A	B	R3241305	
	1/3	A	C	R3241306	
	1/1	A	B-C	R3241107	
	1/2	A	B-C	R3241208	
	1/3	A	B-C	R3241309	

